

Chemistry on the Moon: The Quest for Helium-3

by Natalie Lovegren

"If God had wanted man to become a spacefaring species, he would have given man a moon."

—Krafft Ehrlicke

The unique presence of helium-3 on the Moon will provide an abundant and powerful source of fuel for energy on Earth, and will be the basis for exploration of and settlement on other heavenly bodies. Attaining this superior fusion fuel will be the keystone to any proposed program for economic development for any nation on Earth or for any advances in space. It is estimated that there are at least one million tons of helium-3 embedded in the lunar surface. One ton of helium-3 can produce 10 GW of electrical energy for a year. This means that with less than the equivalent of two Space Shuttle payloads, we could power the United States for one year.¹ In total, lunar helium-3 is estimated to be able to power the Earth for over 1,000 years.

Helium-3 fusion fuel, and the economic transformation that it will bring about on Earth will allow us to begin to take advantage of the myriad opportunities awaiting us on the Moon, as a crucial first step in the economic development of the rest of the Solar System.

1. This is for reference. The Space Shuttle would not be transporting helium-3. Its payload was approximately 32 tons. At current U.S. electricity consumption of 444 GW, and 10 GW electricity produced per ton of helium-3, this would require the equivalent of 44 tons, less than two shuttle loads.

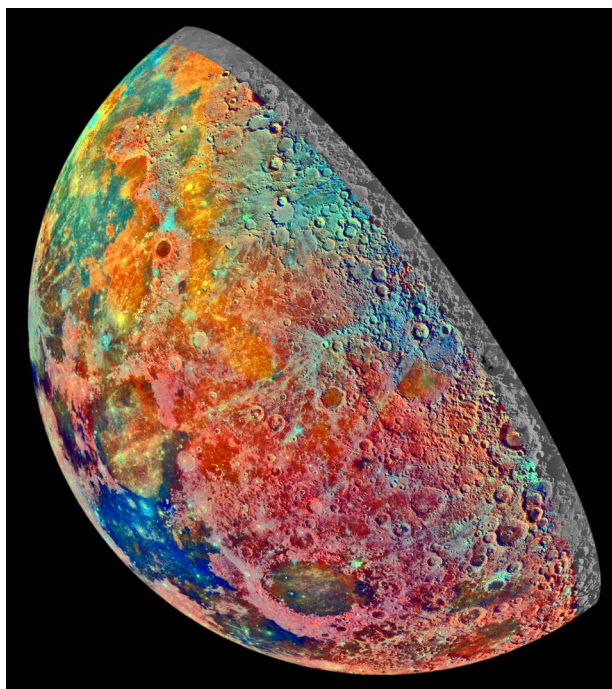

False-color mosaic constructed from 53 images by the Galileo Orbiter's imaging system, during a December 7, 1992 flyby. The dark blue represents a titanium rich area.

The energy released in a deuterium-helium-3 fusion reaction is 18.4 MeV, making it the most energy dense fusion reaction known in terms of net energy gain.² Because helium-3–deuterium fusion reactions are mostly aneutronic,³ the charged particles and electromagnetic radiation that are produced instead can be converted directly into electricity. This enables us to bypass the inefficient and outdated steam cycle altogether, resulting in a doubling of net electricity yield.⁴

The non-electric applications of helium-3 fusion will be an integral part of the fusion economy. Helium-3 makes a superior fuel for propulsion not only because the higher energy density enables greater power, but because the charged particle fusion

products can be magnetically controlled to propel the rocket. The protons yielded from a helium-3–deuterium reaction will be an important source of medical isotopes. The Peaceful use of Nuclear Explosives (PNE) utilizing he-

2. The more common deuterium-tritium reaction yields 17.6 MeV.

3. They produce less than 5% of their energy in the form of neutrons.

4. All thermal systems using a steam cycle are limited to 40% net thermal conversion efficiency (although use of waste heat can slightly raise this). Aneutronic fusion that yields charged particles and electromagnetic radiation can achieve a 60–85% conversion efficiency.

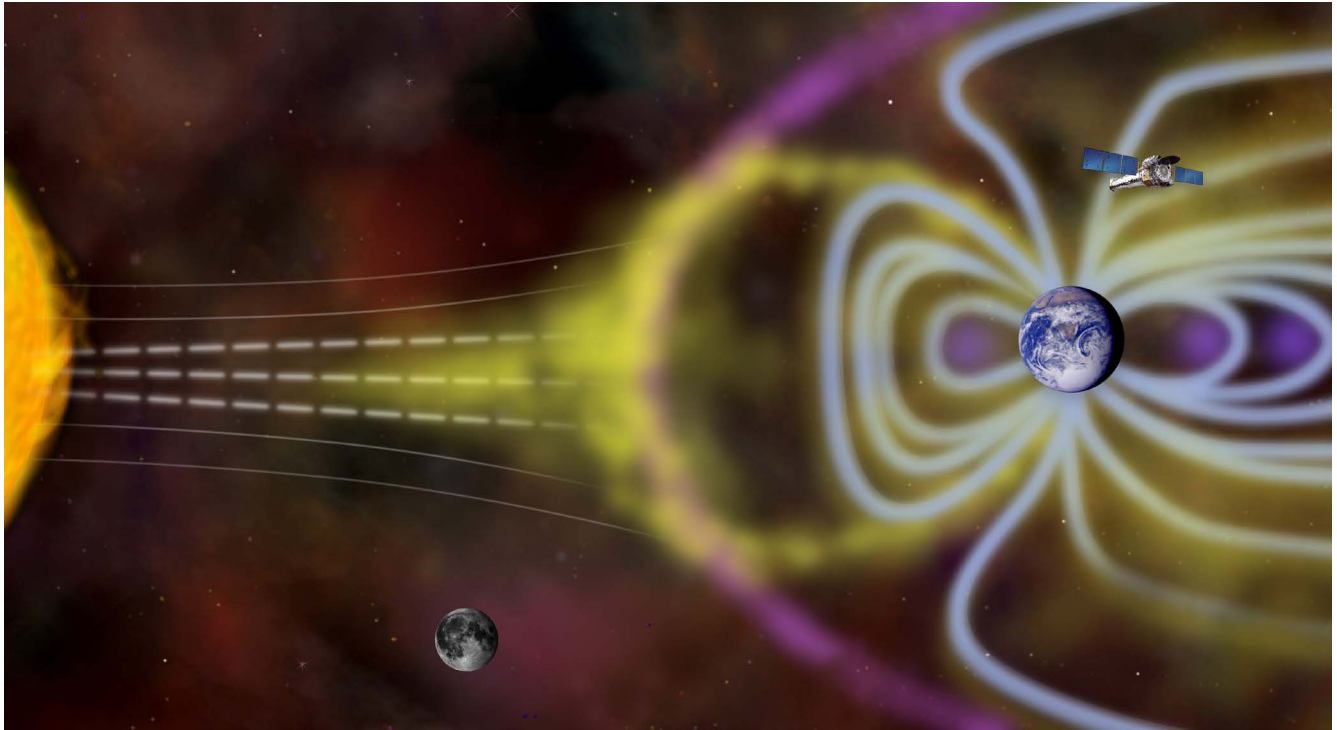

NASA

While the solar wind is deflected by the Earth's magnetic field, the Moon is left exposed, and elements such as helium are implanted into its surface.

lithium-3 fuel will be a necessary technology for advanced construction projects on both the Earth and Moon.

These are only a few examples of the opportunities awaiting us on our estranged satellite. How shall we begin their realization?

Any serious journey, especially one whose goal is settlement, begins with consideration of *in situ* resource utilization (ISRU).⁵ What resources exist in the new territory that are beneficial for immediate and/or long-term use? How did those "resources" come to exist, and what do they tell us about the nature of the new environment we propose to inhabit?

The quest for resources in any foreign territory does not function as a mere search for known resources in familiar form, but must begin with a survey of the new land, with an eye toward universals. What new shape will known scientific principles take, and what unknown principles may we have the opportunity to uncover in a new world? Will such discoveries redefine what resources are?

On the Moon, this investigation begins with an inquiry into the nature of the lunar soil. Lunar soil is the product of a unique evolution and dynamic relationship between the Earth, Moon and Sun. It is a substance unlike any in the known universe, and our mastery of it will lay the

foundation for the progress of mankind, from the development of a fusion economy⁶ on Earth through the conquest of interstellar space.

Chemistry of the Moon

Lunar soil has a similar composition to Earth's crust, composed mostly of silicon dioxide, iron, calcium, aluminum, magnesium, and smaller amounts of titanium, noble gases and other elements. But, while the ingredients are very similar, the means by which they have been arranged are quite different than those of Earth, such that lunar soil can not truly be simulated in a laboratory. The Earth is protected by two major barriers to space weather: a magnetic field, and an atmosphere. The absence of these factors on the Moon leaves its surface exposed to extreme space weather, including solar wind, meteorites, and cosmic radiation.

As the Sun burns up its hydrogen fuel in nuclear fusion reactions, it expels a mixture of elements in plasma form, called the "solar wind." The solar wind is composed of approximately 96% hydrogen, 4% helium, and trace amounts of other elements. These ionized particles, which are electrically charged, are blocked by Earth's magnetic field. The Moon, however, is exposed to the

5. *In situ*—"on site." This refers to using materials that are found on location as opposed to transporting them from Earth.

6. See Fusion: Basic Economics, in this report.

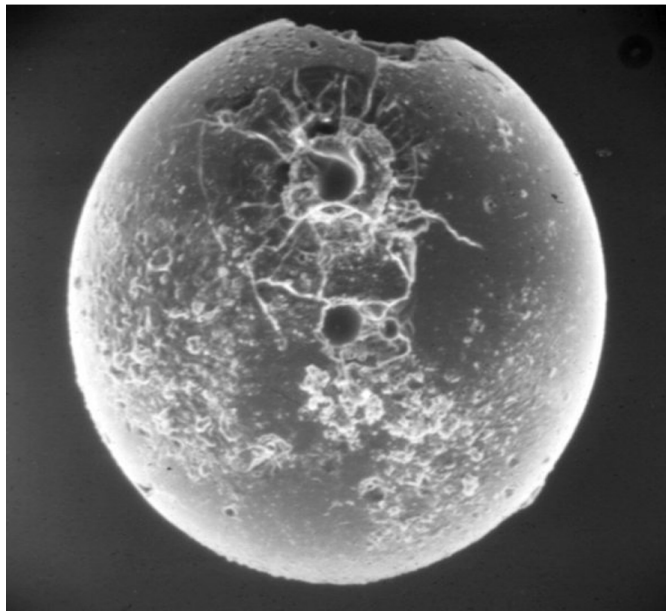

David S. McKay, NASA/JSC

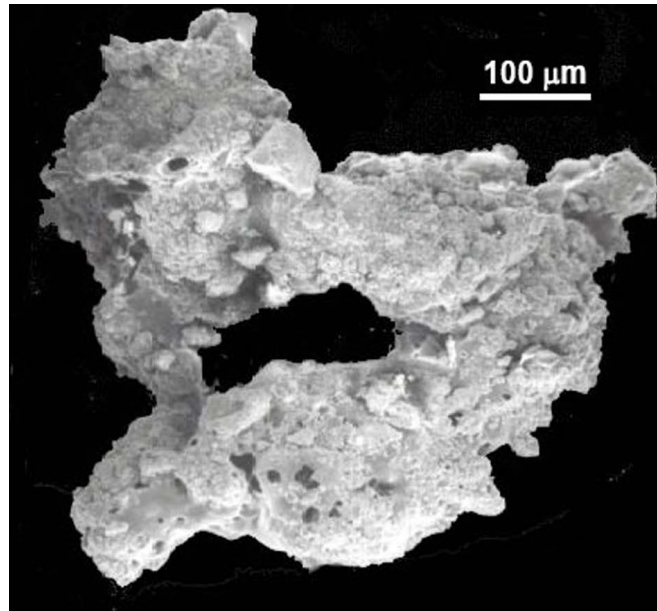

David S. McKay, NASA/JSC

Left: Lunar glass sphere with impact craters from micrometeorites. Right: Glass, rock, and metal, welded together by impact heat from micrometeorites. Smaller than the tip of a mechanical pencil.

solar wind, and approximately 80% of incident ions are implanted into its surface, reacting chemically with the other minerals present. The solar wind is responsible for the presence of helium-3 and other volatiles on the Moon.

Approximately 25 million micrometeorites bombard the lunar surface every day, and as many would also reach the Earth's surface were it not for our thick atmosphere that slows them down, or burns them up through friction.⁷

Even the smallest micrometeorites—measuring some tens to 150 micrometers (microns)—with nothing to impede them, hit the lunar surface at full speed, with velocities of 40,000–250,000 km/hr.⁸ These impacts have pulverized the lunar surface, for over 4 billion years, into a blanket of sand and dust, called “regolith,”⁹ of varying degrees of fineness. Although these micrometeorites

7. There are, however, more formidable space rocks which are big enough to make it through the Earth's atmosphere, and do pose a threat. Between 2000 and 2013, sensors operated by the Nuclear Test Ban Treaty Organization detected 26 explosions on the planet ranging in energy from 1 to 600 kilotons, all caused by asteroid impacts. For comparison, the nuclear bomb that flattened Hiroshima in 1945 produced an energy of 15 kilotons. A comprehensive planetary defense program to monitor and redirect hazardous incoming asteroids should be implemented as an urgent and serious matter of security.

8. McCord, T. B. et al. Sources and physical processes responsible for OH/H₂O in the lunar soil as revealed by the Moon mineralogy mapper (M3). *J. Geophys. Res.* 116, E00G05 (2011)

9. Regolith is a heterogenous coating of broken rock, sand, dust, and soil covering solid bedrock. It comes from the Greek words for “blanket rock.”

range in size from about the width of a human hair down to sizes invisible to the human eye, they carry tremendous energies, due to the high speeds at which they travel, and can generate impact temperatures which can reach 3,000°C.

This results in a regolith which is a mixture of crushed rock, dust, and glass, formed by the high impact temperatures melting silica. These components are also glued together with this hot impact glass to form “agglutinates” of varying grain size. Many of these finer grained particles are so irregularly shaped, that the soil as a whole is very porous, with each grain typically possessing a surface area eight times¹⁰ that of a sphere of equal radius.

During the Apollo lunar missions, astronauts found this soil a bit trickier to deal with than expected. The jagged dust particles were very abrasive, scratching up camera lenses and delicate scientific instruments, and wearing straight through multiple layers of kevlar¹¹ on their boots. The dust easily wore through the high-tech vacuum seals on soil sample boxes, rendering the boxes useless for preventing contamination.¹² When astronauts would return to the lunar module after expeditions, the

10. Taylor, L.A., and Meek, T. T., (2005). “Microwave Sintering of Lunar Soil: Properties, Theory, and Practice” *J. Aerospace Eng.*, ASCE

11. Kevlar is an extremely strong organic fiber, originally developed to replace steel in radial tires, and now used in personal armor such as combat helmets and ballistic vests.

12. Scientists at Oak Ridge, where they were designed, would later joke about the dust-ruined sample boxes, referring to them as “million-dollar shoe boxes.”

dust that had stuck to the space suits¹³ would float around in the cabin, where the very small particles could be inhaled. This caused some astronauts to develop “lunar hay fever.”

While the composition and texture of this soil is essentially what you would expect from rock being constantly broken into bits by high impact projectiles, analysis of Apollo lunar samples revealed several curious phenomena that puzzled lunar scientists.

First, the finest dust particles could not be separated from each other. They were somehow stuck together into clumps,¹⁴ like wet sand. Secondly, they were darker and spectrally redder than the rocks from which they should have been formed.

In 1975, Bruce Hapke of the University of Pittsburgh hypothesized a process that would play a central role in explaining these phenomena: vapor-deposition.¹⁵

A very small and very fast projectile creates a very high concentration of energy upon impact. For comparison,

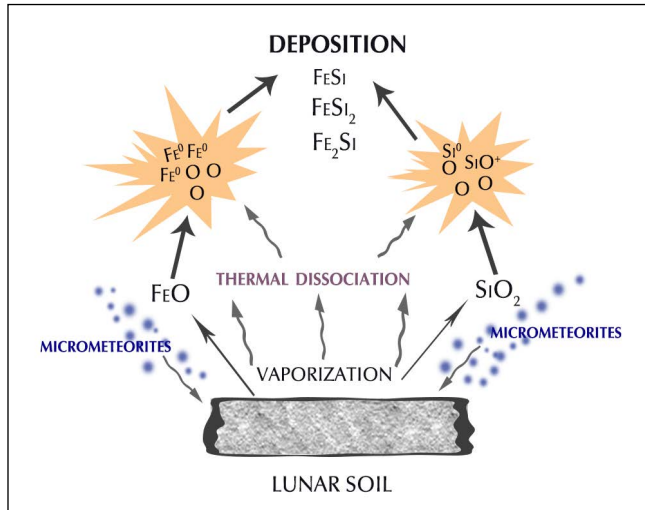

Adapted from Lawrence Taylor

The lack of an oxygen atmosphere on the Moon creates a unique environment for the formation of different chemical compounds. Oxides of iron and silicon present in the soils are vaporized through the high energy impacts of micrometeorites, and then recombine, leaving the oxygen behind.

13. Astronaut-Geologist Jack Schmitt fell down in the regolith so much, that he was prevented from completing his EVAs. Each time he fell (mostly due to geological excitement), more dark gray dust stuck to his suit, darkening the white, reflective surface, and heating it up to potentially dangerous temperatures.

14. Astronaut-Geologist Jack Schmitt fell down in the regolith so much, that he was prevented from completing his EVAs. Each time he fell (mostly due to geological excitement), more dark gray dust stuck to his suit, darkening the white, reflective surface, and heating it up to potentially dangerous temperatures.

15. Taylor, L.A., and Meek, T. T., (2005). “Microwave Sintering of Lunar Soil: Properties, Theory, and Practice,” *J. Aerospace Eng.*, ASCE.

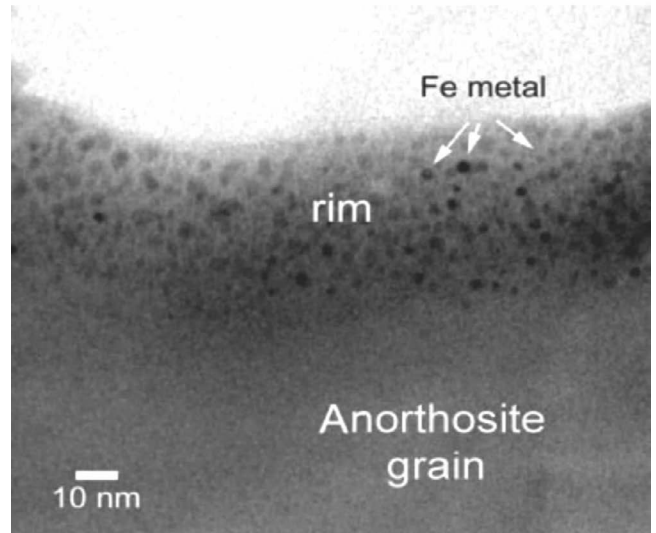

Keller et al., 1999; Pieters et al. 2000

Mature lunar soil, exhibiting a rim of iron (Fe) nanoparticles.

one of the world’s fastest bullets¹⁶ travels at 4,500 km/hr. A micrometeorite traveling at 225,000 km/hr is thus shot at the Moon fifty times as fast as this high speed bullet.

What happens to rocks and minerals when they are exposed to such a density of energy upon impact? For one, there is a tremendous release of heat. Impact temperatures can reach upwards of 3,000°C. Silicon dioxide (SiO₂), the main component of lunar soil, melts between 1,600° and 1,725°C, forming glass when it cools. Iron melts at 1,538°C, and aluminum at 660°C. But once you start getting close to 3,000°C, all of these substances vaporize, and turn into gases. Iron vaporizes at 2,862°C.

Under these high temperatures, solid rock and metal are turned into gas, and molecules are broken down into their constituent elements through thermal dissociation. If this type of process were to occur on Earth, these elements¹⁷ would likely recombine as oxides in the air by attracting oxygen from the atmosphere. The near vacuum of the Moon, however, lacks that oxygen, and these former oxides are given the option to recombine without it.

Hapke hypothesized that metallic iron would be one of the elements vaporized and re-condensed onto the glass surfaces of shock-melted silicate dust particles, and that if it were present, this could explain the discrepancy in optical properties. But, there was no visible evidence for this alleged iron in Apollo lunar samples, even when examined by the best optical microscope.

Then, almost twenty years later, in 1993, Lindsay Keller and David McKay examined lunar dust using a transmission electron microscope (TEM), and found nanophase-

16. From a .220 Swift rifle cartridge.

17. Specifically, the elements shown in the image—iron and silicon.

sized¹⁸ elemental iron beads embedded in the top layers of silicate impact glass.

It was later demonstrated that virtually all mature particles of lunar dust possessed thin patinas and embedded beads of nanophase elemental iron (np-Fe⁰). This discovery accounted for the clumping effect of the fine grains. The iron, present in its zero-valent, elemental form, Fe⁰, made the fine-grain soil magnetic.

Hapke's vapor-deposition model was proven in 2000 when a lunar meteorite was found in Oman, containing a new mineral, unknown to Earth—Fe₂Si. The new mineral was named Hapkeite. Hapkeite proved the vapor-deposition model, but it didn't explain the presence of the lone elemental iron.

Another curious observation further developed the model for space weathering. The fine lunar dust samples contained ten times more magnetic elemental iron than the rocks which it had supposedly been crushed from. The rocks contained iron oxide (FeO), which somehow ended up as plain iron (Fe⁰) when pulverized into dust. So, it was not simply being crushed by meteorites. Was there an outside source, such as iron meteorites that was adding the elemental magnetic iron? Analysis of the soil for meteoritic contamination resulted in a mere 2%.¹⁹

The high impact energies of the micrometeorite bombardment were sufficient to cause the dissociation of the iron and oxygen, but if the iron was being left alone, what had become of the oxygen? There seemed to be another process at work.

Did the constant influx of solar wind play a role? In addition to the relatively small portion of helium, the solar wind was implanting many more ions of hydrogen into the lunar surface. These solar wind-implanted protons would be left lying around in the regolith with their positive charges, awaiting something negative to bond with.

When one of these high-energy meteorites then hit the surface, it would break apart iron oxide molecules, freeing up the oxygen, and exposing it to the vulnerable solar wind-implanted hydrogen ions. The impact energy of the high-speed²⁰ solar wind particles themselves, was also

18. The diameter of an average human hair is about 100 microns. A micron, or micrometer is 1,000 times larger than a nanometer. Even blood cells are still measured in microns; measuring only a few microns, they are too small to be seen. Viruses, proteins, and DNA are all measured in nanometers. Even atoms measure on the level of tenths or hundredths of nanometers. The iron pieces in the lunar dust measure from 3 to 30 nanometers—not much bigger than an individual atom.

19. Taylor, L.A., and Meek, T. T., (2005). "Microwave Sintering of Lunar Soil: Properties, Theory, and Practice," *J. Aerospace Eng.*, ASCE

20. Protons, which comprise ~95% of solar wind particles, have an



A fine-grained lunar soil sample from Apollo 11 is easily attracted by a hand magnet.

sufficient to effect individual atoms in the regolith, and played a part in creating the iron patinas by a process known as "sputtering."²¹ The violent meteorite impacts leave many dangling bonds waiting to be fulfilled, and the ultra-high surface area/porosity of these irregularly shaped particles allow for even higher chemical reactivity, resulting in an overall process which is very volatile.

The only problem with the solar wind implanted proton hypothesis was that hydrogen plus oxygen generally results in H₂O. That is, the reduction of iron from iron oxide, in the presence of solar wind protons, should have resulted in metallic iron and water as products (FeO + H → Fe⁰↑ + (OH)↑, or FeO + 2H → Fe⁰↑ + H₂O↑), but the lunar surface appeared to be bone dry.

There was no evidence of water on the Moon, and none was found in the Apollo samples during the 1970s.

More than 30 years later, in 2008, India launched their first mission to the Moon. This may have been the most exciting thing to have been accomplished in lunar science since the Apollo mission. The Chandrayaan-1 orbiter included a Moon Impact Probe (MIP) which would strike the South Pole, in order to eject underground soil for analysis. The lunar satellite carried high resolution remote sensing equipment, including NASA's "Moon

incident energy range of ~300-1500 eV and average energy of ~500 eV under normal solar wind velocities of 300-800 km/s. Heavier ions, such as helium, carry even greater energies.

21. Sputtering is a process whereby solar wind particles bombard soil grains, causing molecules/atoms to be ejected from a lattice site, and then re-deposited as a thin film wherever they land.

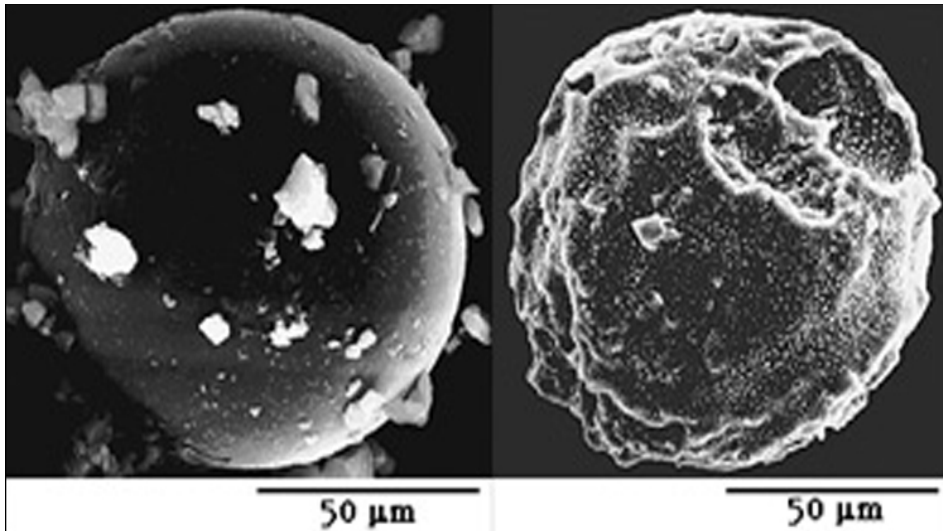

Apollo 17 glass bead before and after being reacted with hydrogen at 1100°C for three hours, in a laboratory. The hydrogen reacted with iron oxide in the glass bead, yielding metallic iron and water vapor.

Minerology Mapper” (M3), designed to survey the mineral content of the entire surface of the Moon. In 2009, both India’s MIP and NASA’s M3 detected clear signatures of water.

In 2012, the solar wind was confirmed as a source for water on the lunar surface.²²

Distinguished geologist and lunar scientist Lawrence A. Taylor, from the University of Tennessee’s Department of Earth and Planetary Sciences had been pursuing this hypothesis for years, and his work on this mission (M3) provided more evidence to support this model. Taylor and research assistant professor Yang Liu analyzed a lunar dust agglutinate, and confirmed the presence of hydroxyl (OH) of solar wind origin:

Analyses²³ of Apollo samples... reveal the presence of significant amounts of hydroxyl in glasses formed in the lunar regolith by micrometeorite impacts. Hydrogen isotope compositions of these glasses suggest that some of the observed hydroxyl is derived from solar wind sources. Our findings imply that ice in polar cold traps could contain hydrogen atoms ultimately derived from the solar wind, as predicted by early theoretical models of water stability on the lunar surface.

22. Solar wind was confirmed as a source for surface water, but it had been shown the previous year that icy comets were a source of interior water. Greenwood, J.P., et al. (2011) “Hydrogen isotope ratios in lunar rocks indicate delivery of cometary water to the Moon.” *Nature Geoscience* 4, 79–82 (2011).

23. Liu, Y., et al. (2012) “Direct measurement of hydroxyl in the lunar regolith and the origin of lunar surface water” *Nature Geoscience* 5, 779–782.

A 1975 laboratory experiment, repeated in 1994,²⁴ had simulated the ability of solar wind hydrogen to be used as a reducing agent to isolate iron, and produce water.

We have thus identified an Earth–Moon–Sun system, where the accelerated solar wind plasma drives the creation of water, advanced fuels for thermonuclear fusion (helium-3), and a unique soil which will serve as an efficient feedstock for construction materials. The interaction of the Solar Wind with the surface of the Moon has created an environment and opportunity unlike any other in the known universe. The Moon, as developed

by the Sun, is the next perfect step for the progress of mankind.

Microwaving Lunar Soil

Larry Taylor was in ground control at NASA’s Johnson Space Center during the last Apollo mission in December 1972, assisting astronauts Eugene Cernan and Harrison Schmitt during their EVAs.²⁵ Taylor and fellow geologist Harrison “Jack” Schmitt would work together in subsequent years, studying Apollo lunar soil, and making numerous discoveries regarding the environment on the Moon, and how to best return there to settle it.

In the years preceding the discovery of lunar water, Taylor and colleagues (Thomas Meek et al.) had made another striking discovery about the lunar dust, with great implications for the development and colonization of the lunar surface.

One day, they decided to see what would happen if some Apollo 17 lunar dust were heated up in the office microwave. Microwaves do strange things to ordinary objects like grapes, bars of soap, Peeps, etc., so why not try one out on such an extraordinary substance as lunar dust? To their amazement, the small vial of lunar dust melted within minutes.

24. “Brecher et al. (1975) reduced a sample of Apollo 17 orange glass with hydrogen at 800°C in a closed reaction vessel. Our reduction experiments on this same material were run at temperatures of 900 - 1100°C. In all cases significant portions of the iron oxide in the glass were converted to micrometer-scale iron metal blebs, with concomitant release of oxygen. At the same time, the glass devitrified to a fine-grained mixture of pyroxene and plagioclase crystals.”

25. EVA: Extra-vehicular activity, a.k.a., moon walks.

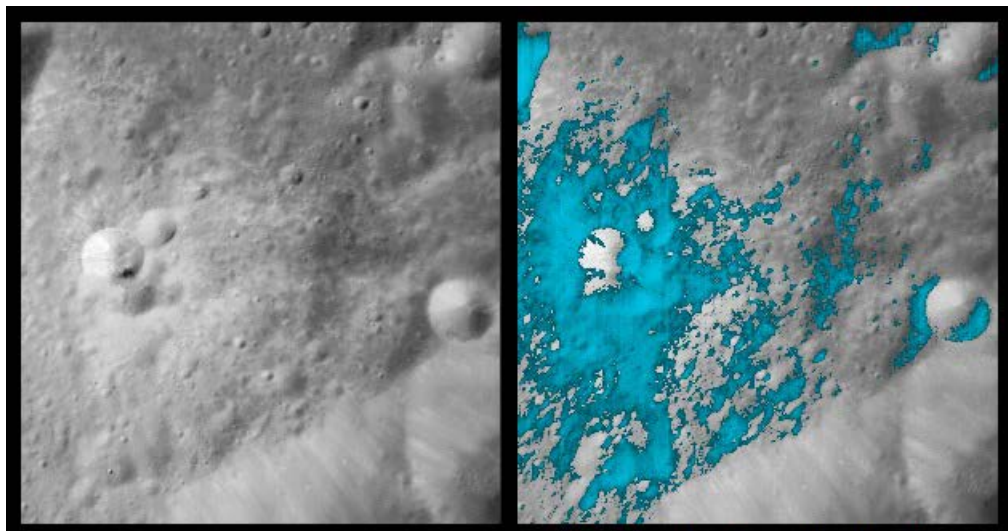

Source

A young crater on the far side of the Moon imaged by the Chandrayaan-1 Moon Mineralogy Mapper, using infrared reflectance. Water-rich minerals are shown in blue.

They found that the lunar soil could be heated up to 1200°–1500°C, and melted, in a regular 2.45 GHz kitchen microwave, almost as fast as it takes to boil water for tea (at 100°C)! A strange interaction between the properties of the soil, and the microwave energy was occurring.

This phenomenon brought them back to the discovery of the nanophase metallic iron present in the lunar soil. It is commonly understood that it is not prudent to place metal in a microwave. Solid, non-porous bulk metals are opaque to, and will reflect microwaves, causing sparks, and possible reflection back to the magnetron, which could short-circuit and damage the machine. Other materials, such as glass, are transparent to microwaves, while water molecules in food respond to the microwave, by vibrating, and heating up the food.

A lesser known fact is that a metal in a powdered form will absorb microwave energy very well, and rapidly heat up. Powdered metal acts as a conductor, separated by an insulator (the air), and is efficiently heated. This phenomenon was discovered and patented in 1999, for use in industrial processes. The way that the material is heated depends on the frequency of the microwave, and the type of insulator used. Microwaves can be tuned to different frequencies to best couple with the properties of the given material. Glass has a high electrical resistivity, and makes a good electrical insulator—a dielectric.²⁶

Basically, the minute size of the nanophase metallic Fe is small enough such as to be less than the skin depth of the microwave energy. This makes each of the metallic

Fe grains into a conductor [versus typical reflector], separated from the other metallic Fe particles by the dielectric glass. The conductor abilities of the metallic Fe act as an absorber of the microwave energy, thereby creating “energy sinks” with the effective generation of large quantities of heat...

No lunar simulants exist to study these microwave effects; in fact, previous studies of the effects of microwave radiation on lunar simulants, MLS-1 and JSC-1, have been misleading. Using real Apollo 17

soil has demonstrated the uniqueness of the interaction of microwave radiation with the soil... [W]e now appreciate the cause for the unique behavior of lunar soil with microwave radiation, and it cannot be emphasized enough that this is an unusual property for any naturally occurring material. —Taylor and Meek 2005

The implications for this effect are enormous.

Sintering

This unusual property is ideally suited to an industrial process called “microwave sintering.”

Sintering is a method for forming objects by heating a powdered material in a mold. The powder—whether metal, ceramic, or plastic—is heated to a high temperature, but one which remains below its melting point. This allows molecules to fuse together, welding particles to each other without having to fully melt the material. It is used to create alloys and shape metals with high melt-

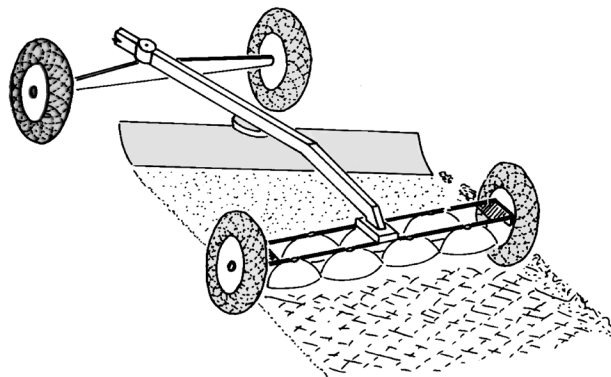

Lawrence Taylor

Microwave sintering lunar paver.

26. For comparison, it takes a specially prepared noble gas environment, and more than 90 minutes for terrestrial metals to reach 1600°C—a temperature that microwaved lunar soil can reach in about 2 minutes. *Materials World*, Vol. 7 no. 11 pp. 672-73 November 1999.

ing points, which would otherwise require a significant amount of energy to be expended in melting. The process creates durable, uniform, high-strength objects, utilizing less energy than traditional casting practices.

Microwave sintering takes advantage of the special coupling property of microwave energy and powdered metals, creating an even more efficient process than conventional heating used in sintering. The presence of $\eta\text{-Fe}^0$ in lunar soil provides yet even greater advantages for microwave processing. The combination of rapid heating rates ($1000^\circ\text{C}/\text{min}$) to high temperatures (2000°C), faster reaction rates at lower sintering temperatures, improved mechanical properties, and process simplicity, results in a highly energy efficient and qualitatively advanced means of creating construction materials. The possible applications of microwave processing of lunar soil are seemingly endless.

In recent years, with Apollo 17 soil allocated by NASA, Larry Taylor has invented various products and mechanisms for ISRU on the Moon.

His “lunar road paving wagon” carries two sets of magnetrons that can be tuned to different microwave frequencies, depending on the properties of the soil it would drive over to pave. The paving wagon would utilize a blade to smooth the regolith, and two rows of magnetrons for sintering and melting. The first set would sinter the soil to a depth of 0.5 m, and the second would completely melt the top 3–5 cm of soil, allowing the surface to solidify into smooth glass. This type of vehicle could be used to create paved roads, launchpads, runways, and dust-free lots for astronomy or industrial operations. Blocks of soil could be sintered to form the solid bricks required to construct bases and other structures.

Impact craters could be smoothed out into parabolic surfaces, and then vitrified to produce antenna dishes. Such a crater dish could be cut into sections, and re-assembled for placement into orbit. Lunar dust is also very efficient at blocking radiation, and will be ideal for shielding astronauts from cosmic rays.

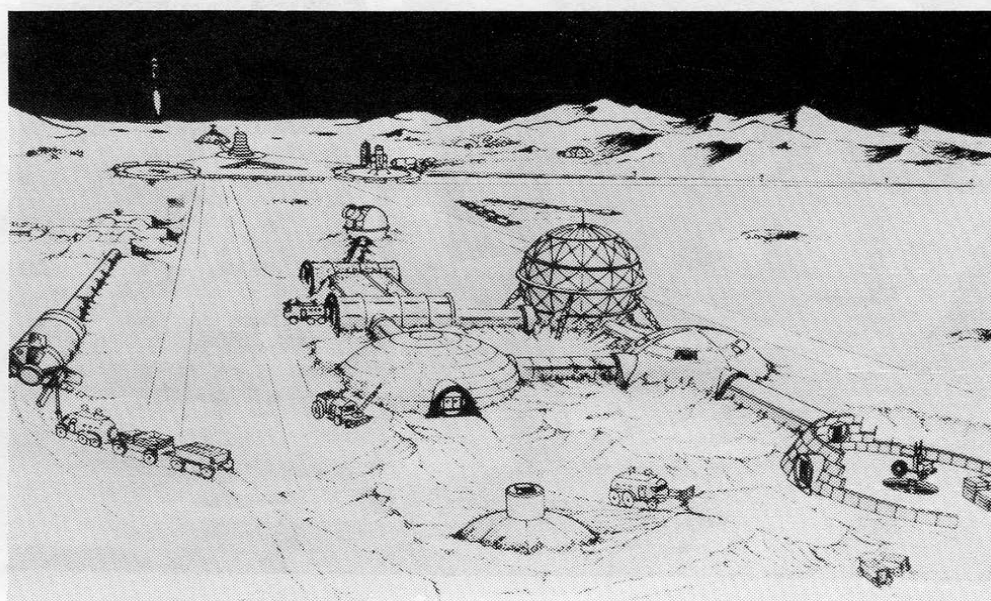

NASA

Artist's concept of a lunar base.

Mining Helium-3, Air and Water

A vehicle such as the lunar paver would release solar-wind particles trapped inside the soil as it passes over and heats it up. The lunar paver could therefore double as a gas extractor, or a separate non-paving microwave vehicle could be used solely for mining and collecting trapped solar wind gases. This means that hydrogen, oxygen, helium (^3He and ^4He),²⁷ and other noble gases could be efficiently mined using microwave energy. The gases could be extracted together, then separated by cooling them down. As absolute zero is approached, each gas will become liquid at a different temperature, allowing them to be separated by phase.

Magnetic Dust

The abrasive, static-clingy, hay-fever-causing, talc-fine dust will not be such a nuisance to astronauts armed with this new knowledge and technology. Magnetic brushes will serve them well to dust off their lenses and clean off their space suits. An electromagnetic air filter will magnetically cleanse the air breathed by astronauts in bases or lunar modules. And the lunar paver could create entirely dust-free zones.

27. Helium-4 is also a valuable resource used in vital high-tech applications such as cryogenics, welding, superconducting (for MRIs, particle accelerators, and the many superconducting tokamaks that will soon be built as we transition to a full-scale fusion economy), and other technologies crucial to industry, research, and medicine. The U.S. National Helium Reserves are running low, and we do not yet have a back up plan. It may be necessary to mine lunar helium-4 for use on Earth, as well.



NASA

The All-Terrain Hex-Limbed Extra-Terrestrial Explorer (ATHLETE) vehicle.

3D Printing

A popular new technology called “3D printing”, or “additive manufacturing” uses a robot to create 3-dimensional objects with a printer head that adds successive layers of material to build upwards, out of the 2D “paper” plane. This method of building up solid objects in layers contrasts with the traditional manufacturing approach of removing material from a solid piece, or casting objects in molds. It can print in over a hundred materials, including plastic, metal, and nylon, and produces serious items such as aircraft engine parts and functional human tissues (using the person’s own cells!).²⁸

In January 2013, the European Space Agency (ESA) teamed up with London architecture firm Foster + Partners to design a 3D printed lunar base.²⁹

Foster + Partners’ concept would use lunar soil to 3D print a weight-bearing catenary dome with hollow-cell segments similar to bird bones, serving as walls. The strong outer wall would shield against radiation and micrometeorites, while an inflatable pressurized inner module would shelter astronauts.

Printer nozzles would first mix the lunar soil with magnesium oxide, which acts like a glue. Then they would add a binding salt to enable the structure to solidify af-

28. “Bioprinting” company Organovo makes biological “ink” from cells of a selected tissue that intersperses cell ink with collagen or hydrogel, building up layers of tissue as is done in 3D printing manufacturing.

29. “Building a lunar base with 3D printing,” January 31, 2013, phys.org.

ter printing. The nozzles³⁰ would have to be inserted beneath the surface of the regolith to protect the liquid “glue” from being boiled away by the vacuum of the Moon.

Wait, you might ask, why use glue when we could weld the dust particles together with a little bit of heat? Why not marry 3D printing technology with microwave sintering? Wouldn’t you then eliminate the need to bring any printer “glue”³¹ to the Moon, while taking advantage of the natural properties of the lunar soil coupling with microwave energy to create extremely strong and precise structures that could be built by robots?

3D Printing Microwave Sintering Space Spiders

It turns out that someone at NASA had the same thought:

SinterHab³² is a concept of a 3D printed module of a Lunar South Pole base that shows the potential of 3D microwave printing technology of NASA. It would be constructed from lunar dust by microwave sintering and contour crafting by NASA ATHLETE robotics system near Shackleton crater. Robots equipped with this technology would basically bake the lunar dust without any necessary glue that would need to be imported from Earth.... An innovative internal inflatable membrane Inflatable space habitat system of SinterHab offers up to four times bigger volume of the module than classic rigid modules at the same weight imported from Earth. Nature provides inspiration for inflatable structures in the form of foam bubbles. The intention of building several compartments with sintered walls led to a design based on the geometry of bubbles, where the forces of neighbouring bubbles are in equilibrium and enable the building of flat walls. It would be possible to make the modules large enough to accommo-

30. Cesaretti, E., Dini, E. et al. (2014) “Building components for an outpost on the Lunar soil by means of a novel 3D printing technology.”

31. The ESA’s tests were successful using a “lunar simulant” composed of basaltic rock from an Italian volcano, which is said to bear a “99.8% resemblance to lunar soil.”...But, the ESA would do well to heed L.Taylor’s warning about lunar simulants. The dynamics of space weathering on the moon are 100% unique to the moon as a whole, and the effect of that system—the lunar soil—is not replaceable with a terrestrial substitute. Lunar simulants can approximate to some extent the physical abrasive properties of lunar soil, but *not* its chemistry.

32. “Sinterhab—3D printed Moon Base,” spacearchitect.org.

date even a green garden that recycles air and water for the lunar outpost...

The SinterHab construction method is based on the MS-FACS. Scientists at NASA JPL have proposed the Microwave Sinterator Freeform Additive Construction System (MS-FACS), a large six-legged multi-purpose robot called ATHLETE holding microwave printer head that would create walls and domes.³³

The SinterHab moonbase would be located at the Moon's South Pole, at Shackleton Crater. The rims of this crater stand in near-perpetual sunlight, which will provide ample solar energy to power the microwaves needed for the Sinterator.

Finding Helium-3

Conveniently, also near the poles, there may also lie a potentially vast reserve of helium-3.³⁴

Extrapolation of the Apollo 11 sample data by remote sensing indicates that the 84,000 square kilometers (~53,000 sq. mi.) of the highest grade regolith on Mare Tranquillitatis contains at least 5000 tonnes (5500 tons) of recoverable helium-3 (Cameron, 1990; Schmitt, 2006, 92–95). That amount would provide 50 years supply (assumed plant life) for 100, 1000-megawatt helium-3 fusion power plants on Earth. Near the lunar poles, 84,000 square kilometers (~53,000 sq. mi.) may supply three times the above number of power plants. Future direct remote sensing and/or sample data from high latitude regions of the Moon may positively influence the calculation of inferred helium-3 reserves as well as the production costs. Where deep permanent shadow exists, helium-3 also may be contained in clathrates and non-lunar fullerenes.³⁵ —*Schmitt, Henley, et al. 2011*

We have answered the question of how helium-3 arrives on the Moon, but why does it stay? Helium-4 on Earth, which is formed by the radioactive decay of heavy elements (such as uranium and thorium), is one of the only elements with escape velocity, and is constantly escaping the Earth's atmosphere, floating right out of the planet and into space. Why wouldn't helium-3 on the Moon behave the same way? What is keeping it on the Moon?

33. "Microwave Sinterator Freeform Additive Construction System (MS-FACS)" (January 2013) NASA/JPL, NASA Tech Briefs.

34. Schmitt, H. H., Henley, H. W. et al. (2010) Lunar Helium-3 Fusion Resource Distribution".

35. Sternfeld, T., Hoffman, R. E. (2002) "Two Helium Atoms Inside Fullerenes: Probing the Internal Magnetic Field in C60 6- and C70 6-" JACS.

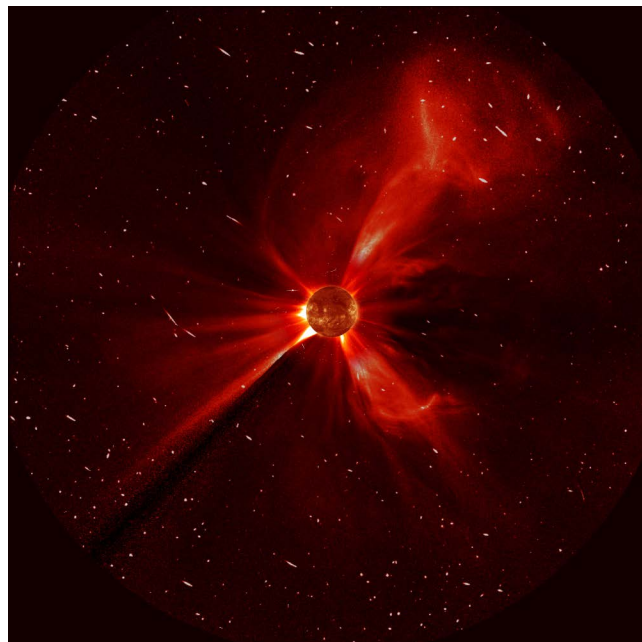

NASA

The solar wind.

Helium, as a noble gas, does not form compounds, i.e., it is not chemically bound up into molecules. However, it may be physically trapped, and held in the pockets of the porous regolith. It appears that some minerals on the Moon are able to trap helium-3 very well. Applying heat causes these gases to be agitated, and released from the crevices in which they hide.

For this reason, studies suggest that abundance of ³He is much higher (42%) than Apollo samples show, due to loss from agitation. Estimates of its mass are as high as 20.5 ppb vs. the 11.8 ppb average of Apollo 11.

Because helium-3 is implanted into the surface by the solar wind, the finest fraction of the regolith—the mature, npFe⁰-containing particles most exposed to and weathered by the solar wind—contains the greatest proportion of ³He.

It has been shown that there is a rough correlation between helium-3 and ilmenite (iron titanium oxide, FeTiO₃) the major titanium mineral on the Moon. It has been demonstrated that ilmenite-rich regolith retains helium-3 better than other minerals do, and also traps it better than hydrogen, helium-4, and other gases. Perhaps helium atoms fit better into the close-packed, hexagonal crystal structure of ilmenite. This would cohere with the fact that helium-3 is released from the regolith at a wide range of temperatures (300°C–800°C), i.e., it seems that some minerals hold it more tightly than others, requiring higher temperatures to disturb it for release.

In order to indirectly map out helium-3 distribution, titanium distribution can be measured with remote spectrometric analysis from Earth or from lunar orbit, as has been shown by the Clementine Lunar Prospector.



Craters on the lunar surface.

Schmitt hypothesizes that helium-3 may also be found in clathrates protected by permanent shadows.³⁶ Clathrates are compounds which are composed of a lattice which acts as a cage to entrap visiting molecules. According to Dr. Manohar Sehgal of DAV College Jalandhar, India,

No helium clathrates are known on the Earth because the sizes of the empty spaces (hole/interstices) in minerals/ores are much larger on the Earth than of helium size (app. 40pm). So, small-sized helium escapes from the large sized holes of the minerals on the Earth. But on the Moon with 1/6 of gravity of Earth, these minerals have small-sized holes where the helium-3 can well fit in and remain embedded in them because now the *guest* and the *host* are held by Van Der Waal's forces³⁷.... The clathrate³⁸ is formed as the atomic size of the guest (³He) and of the holes (empty sites) of the host (ilmenite) are comparable. On the other hand, the holes in anorthite,

36. Schmitt, H. H., Henley, H. W. et al. (2010) "Lunar Helium-3 Fusion Resource Distribution"

37. Van Der Waal's forces: the sum of attractive or repulsive forces between molecules, relatively weaker than the stronger covalent bonds, which bond atoms together through shared electrons.

38. The word "clathrate" comes from the Latin clatratus, meaning "with bars".

olivine or chromite are either narrower (He^3 does not enter) or are wider (^3He escapes), i.e. the ideal value is only reached between the ^3He atomic size and the ilmenite hole size.

Mining Helium-3

According to Harrison Schmitt's estimates in *Return to the Moon*, 100 kg of helium-3 "is more than enough to power a 1,000MW plant for a year when fused with deuterium. This would require the processing of 2 square km of lunar surface to a depth of 3 meters. In turn, that annual rate requires hourly mining of an area about 28 meters square and 3 meters deep along with the hourly processing of the finest 50% of the mined soil (about 2,000 tonnes) to extract its gases. This is not a high mining and processing rate by terrestrial standards and only requires two 10-hour mining shifts per day, 20 days out of each lunar month (about 27 Earth-days long)."³⁹

By virtue of the space-weather "gardening,"—i.e., the continual transformation of the soil by micrometeorites and solar wind—it is the uppermost layer of regolith that is most valuable to us for mining helium-3 and its beneficial by-products. Mining to a depth of 3 meters is negligible by terrestrial standards.⁴⁰

Furthermore, the correlation between grain size, abundance of helium-3, and magnetic properties is quite fortuitous. Because the helium-3 is deposited by the solar wind, and is a result of the weather process which is also responsible for the magnetic properties, it is the more mature, smaller, more magnetic surface layer of the regolith which possesses the most helium-3, the best soil for construction feedstock, and the most valuable volatiles⁴¹ for sustaining life.

Solar wind particles are implanted in only the outer few 100 Å to 1000 Å⁴² of each soil grain (Eberhardt et al.,

39. The energy present in a ton of helium-3 is the equivalent of that present in 6.7 million tons of coal. Compare the amount of manual labor involved in difficult and often dangerous coal-mining operations to the safe and highly-skilled technical labor that will be involved in designing and controlling robots that will mine helium-3. What type of upshift in the quality of human life will this represent?

40. Compare this to the TauTona Mine in South Africa, which mines gold at a depth of 2.4 miles. Helium-3, much more valuable than gold, is practically lying on the surface of the Moon.

41. For every ton of helium-3 extracted, there are 6,000 tons of hydrogen, 500 tons of nitrogen, 5,000 tons of carbon-containing molecules, and over 3,000 tons of the heavier helium-4 isotope, all of which will be extremely valuable for atmospheric control, life support, and chemical fuels during the construction of a lunar base.

42. An Ångstrom is a tenth of a nanometer, or a ten-thousandth of a micron.

1970). Therefore, it is largely the surface areas of the grains which are of importance in considerations of the abundance of He. Inasmuch as the surface area/volume increases with a decrease in grain size of a soil, it is no surprise that solar-wind contents of lunar soils are a function of grain size. Typically about 50% of a soil by weight is <50 micron in size (McKay et al., 1991); however, this fine-sized fraction contains considerably greater total surface area than the >50 micron portion. Consequently, *the <50 microns portion of lunar soils typically contain about 80% of the total He* (Eberhardt et al., 1970). Fully 90% of the He is present in the <100 micron size fraction.⁴³

Furthermore, the by-products of mining helium-3 are the gases essential for sustaining life in a lunar base: oxygen, hydrogen, and compounds of nitrogen and carbon. And as we have discussed, the soil itself is a perfect feedstock for construction materials.

What else will we do on the Moon?

The Moon has many advantageous properties that are not only absent on Earth, but in fact are not found anywhere else in our Solar System. Its low gravity makes it ideal as a launch base for spacecraft by avoiding the tremendous energy expense involved in leaving Earth's atmosphere. The low gravity environment is also advantageous for saving energy in industrial processes. The

43. "Helium-3 on the Moon for Fusion Energy: the Persian Gulf of the 21st Century" L.A. Taylor and G.L. Kulcinski, *Solar System Research*, Vol. 33, No. 5, 1999, pp. 338-345

Moon's "farside" is the only place in the solar system that constantly faces away from the Earth, making it one of the "quietest" places in the solar system, and therefore an ideal location for measurements of the Sun and distant regions of the galaxy in a frequency range that would otherwise be impossible due to interference from the Earth. The Moon's position with respect to the Sun and Earth creates a "lunar wake" in the outward flowing solar wind, which will serve as a unique plasma physics laboratory to advance fusion and other forefront scientific research. Permanently shadowed craters at the lunar poles, considered the coldest places in the Solar System, provide extreme thermal and electrical environments for investigation and for possible placement of telescopes. Permanently sunlit crater rims offer abundant solar energy. These are only a few examples of the unique environment that we will be able to take advantage of with the development of abundant energy and higher power potential offered by a helium-3 economy.

Conclusion

Helium-3, the carefully crafted fossil of the Sun, the ideal fusion fuel, which will power mankind into a new age of progress, has been perfectly trapped on our abandoned satellite, and is simply awaiting our decision to utilize it. We thus have an ideal situation: the lunar soil has been created in such a way, over the past 4.5 billion years, that it is *now* the best possible resource for the advancement of humanity. It almost seems as though it were created with us in mind.